

RITMO AMERICA



"AT EASE IN YOUR JOBSITE"

www.ritmoamerica.com





RITMO S.P.A. is a world leader with over 35 years of experience in the manufacturing of plastic welding equipment. All products are designed and built according to International standards and directives (UNI, ISO, CEE). Since the very beginning, quality and technology innovation are RITMO's milestones, and time after time, this philosophy is always more recognized by the global market. RITMO strong points are its ideas to design and produce accurate, fast, versatile, modular and easy-to-use welding machines. Products range includes butt fusion, electrofusion and extrusion equipment. Ritmo is also providing a complete line of accessories and useful instruments for pipe cutting and weld preparation such as the band saws. RITMO's regards towards the client has brought to the new-born "RITMO FUSION OPERATOR SCHOOL", which is a welding school with the goal of building qualified personnel and spread the knowledge about the technical potentiality of RITMO's equipment: **TECHNOLOGY MADE IN ITALY.**

MADE IN ITALY

DESIGNED & MANUFACTURED
IN ITALY



watch the video



ISO 9001
Quality System

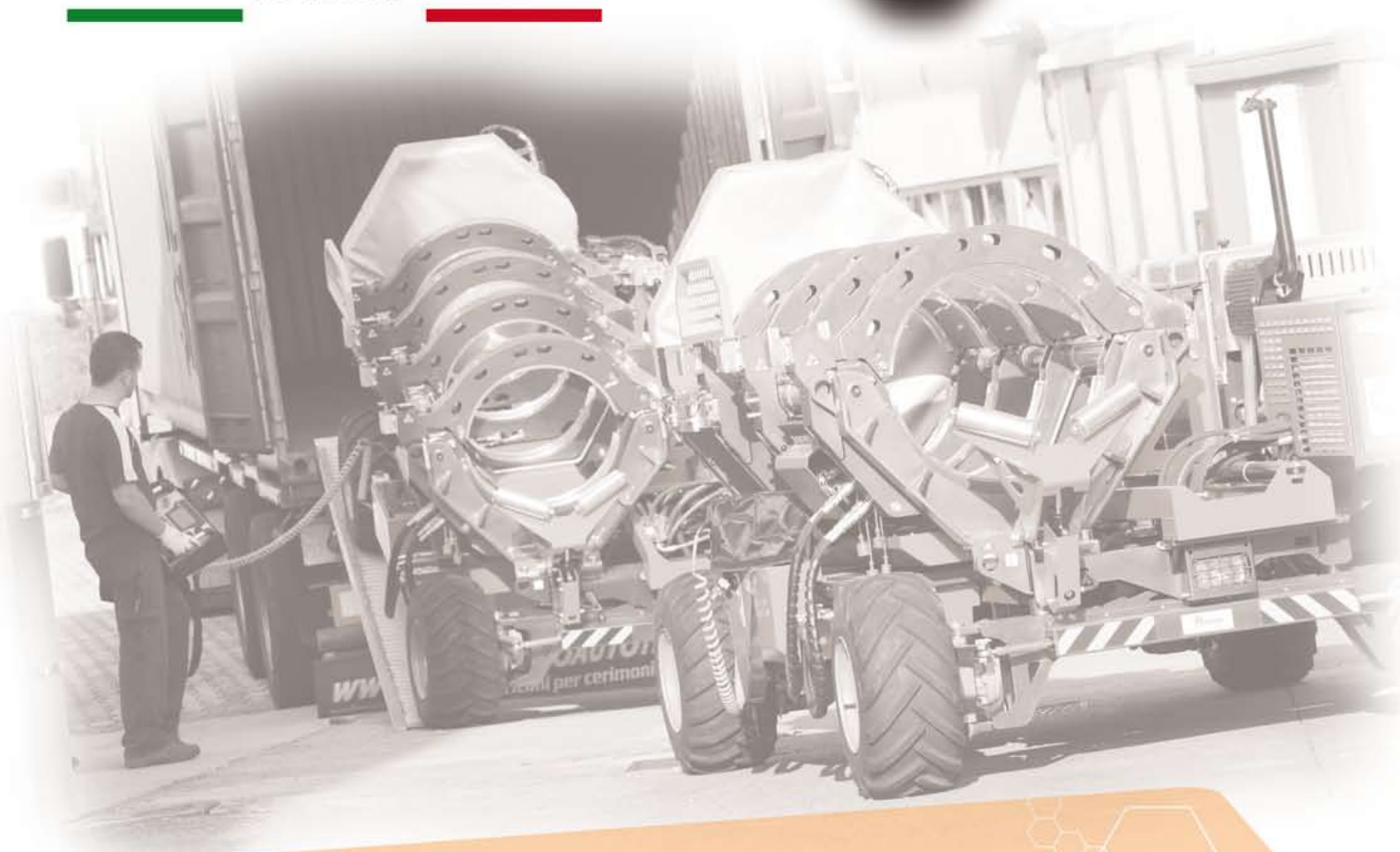



Ritmo America LLC - FL

RITMO AMERICA

www.ritmoamerica.com



Rossella Contiero - Managing Director



Follow RITMO on



www.youtube.com/user/RitmoPlasticWelding

A

D V A N T A G E

RITMO SERVICE

RITMO WORLDWIDE

Ritmo has professional distributors and resellers all over the world. Our staff is ready to assist you in English, Spanish, French, German, Arab, Italian, Russian and Portuguese.

TRAINING

From many years now, we have decided that the best way to grant a client/distributor a perfect knowledge of our products is to invest in custom training, in our own premises. These courses are aimed to teach how to operate the products in the best way, and how to supply the "first aid" when necessary.

PRESALES TECHNICAL ASSISTANCE

When a client or a potential client wants to buy us a product, it is our standard procedure to help find the best solution to its needs.

GLOBAL ADVICE

In such a technical field as ours, the customer requires the best assistance. Thanks to the experience developed along the years, and to the co-operation with several manufacturers, institutions, schools and training institutes, RITMO is able to give the most comprehensive advice to no matter which related issue.

Our company is a long-time member of a UNIPLAST's (UNI-Italian National Plastics Standards Body) working group dedicated to the study and draw up of new standards within our field. The importance of this group is linked to the fact that the expansion of the plastic welding field ought to be followed by a crescent sensitivity for safety issues, so to have a sustainable and continuous growth. The working group prepares draws, hence present them to the UNI to be discussed and eventually transformed into new standards.

AFTER SALES TECHNICAL ASSISTANCE

Ritmo's Service Centre can solve all kind of technical issues, as well as overhaul our machines. Ritmo has other Service Centres abroad, linked to its official distributors.

STARTING AND TESTING

RITMO' technicians are prepared to make the starting and testing of workshop machines at the client' own premises, so that the fittings production can start almost immediately.

BUTT FUSION MACHINES



WORKING RANGE

| MODEL | IPS | DIPS | 1 | 1¼ | 1½ | 2 | 3 | 4 | 5 | 6 | 8 | 10 | 12 | 14 | 16 | 18 | 20 | 22 | 24 | 26 | 28 | 30 | 32 | 34 | 36 | 40 | 42 | 48 | 54 | 60 | 63 | | |
|-----------------------|------|------|----|----|----|---|---|---|---|---|----|----|----|----|----|----|----|----|----|----|----|----|----|----|----|----|----|----|----|----|----|--|--|
| | | | | | | | | | | | | | | | | | | | | | | | | | | | | | | | | | |
| DELTA 160 M | | | | | | | | | | | | | | | | | | | | | | | | | | | | | | | | | |
| BASIC 160 EASY LIFE | | | | | | | | | | | | | | | | | | | | | | | | | | | | | | | | | |
| DELTA DRAGON 160 | | | | | | | | | | | | | | | | | | | | | | | | | | | | | | | | | |
| BASIC 200 EASY LIFE | | | | | | | | | | | | | | | | | | | | | | | | | | | | | | | | | |
| DELTA DRAGON 250 B | | | | | | | | | | | | | | | | | | | | | | | | | | | | | | | | | |
| DELTA 250 TRAILER | | | | | | | | | | | | | | | | | | | | | | | | | | | | | | | | | |
| BASIC 315 EASY LIFE | | | | | | | | | | | | | | | | | | | | | | | | | | | | | | | | | |
| DELTA 355 ALL TERRAIN | | | | | | | | | | | | | | | | | | | | | | | | | | | | | | | | | |
| DELTA 355 TRAILER | | | | | | | | | | | | | | | | | | | | | | | | | | | | | | | | | |
| BASIC 355 EASY LIFE | | | | | | | | | | | | | | | | | | | | | | | | | | | | | | | | | |
| DELTA DRAGON 355 B | | | | | | | | | | | | | | | | | | | | | | | | | | | | | | | | | |
| COMPACT 355 L | | | | | | | | | | | | | | | | | | | | | | | | | | | | | | | | | |
| DELTA 500 | | | | | | | | | | | | | | | | | | | | | | | | | | | | | | | | | |
| DELTA 500 EASY LIFE | | | | | | | | | | | | | | | | | | | | | | | | | | | | | | | | | |
| DELTA 500 ALL TERRAIN | | | | | | | | | | | | | | | | | | | | | | | | | | | | | | | | | |
| DELTA 500 TRAILER | | | | | | | | | | | | | | | | | | | | | | | | | | | | | | | | | |
| DELTA 630 TRAILER | | | | | | | | | | | | | | | | | | | | | | | | | | | | | | | | | |
| DELTA 630 ALL TERRAIN | | | | | | | | | | | | | | | | | | | | | | | | | | | | | | | | | |
| DELTA 630 | | | | | | | | | | | | | | | | | | | | | | | | | | | | | | | | | |
| DELTA 630 EASY LIFE | | | | | | | | | | | | | | | | | | | | | | | | | | | | | | | | | |
| DELTA 800 | | | | | | | | | | | | | | | | | | | | | | | | | | | | | | | | | |
| DELTA 1000 TRAILER | | | | | | | | | | | | | | | | | | | | | | | | | | | | | | | | | |
| DELTA 1000 | | | | | | | | | | | | | | | | | | | | | | | | | | | | | | | | | |
| DELTA 1200 | | | | | | | | | | | | | | | | | | | | | | | | | | | | | | | | | |
| DELTA 1600 | | | | | | | | | | | | | | | | | | | | | | | | | | | | | | | | | |
| IPS | DIPS | 1 | 1¼ | 1½ | 2 | 3 | 4 | 5 | 6 | 8 | 10 | 12 | 14 | 16 | 18 | 20 | 22 | 24 | 26 | 28 | 30 | 32 | 34 | 36 | 40 | 42 | 48 | 54 | 60 | 63 | | | |

● On request



DELTA 630 TRAILER



DELTA 630 TRAILER is a self-aligning fusion machine, suitable for welding thermoplastic pipes for the transport of water, gas and other fluids under pressure, up to Ø 24" DIPS (630 mm).

Machine can fuse pipes according to the **ISO 21307 High Pressure standard** (pressure range is three times and a half higher than the ISO Low Pressure ones). This greatly enhances productivity allowing 60% time saving.

Standard machine features:

- **Machine body** mounted on a 4 wheeled chassis, easily removable for working in tight spaces; steel hydraulic clamping with the **fast-locking inserts**, which allows to place and remove inserts in seconds; **self detaching device**: helps removing the heating plate during welding procedure
- **4 wheeled chassis** with 2 steering wheels and a safety brake
- An **on-board hydraulic electric facer** that is equipped with a safety microswitch to prevent from accidental starts, a thermal circuit breaker to protect motor
- An **on-board hydraulic heating plate** Teflon-coated (PTFE) which comes with a high-temperature-proof bag, which also avoid the heating element from being scratched
- An **EASY LIFE control panel** with a large graphic display and **GPS traceability**, which is also removable from the machine body to be able to weld from outside the ditch. Allows the operator to program and pilot all the welding cycle in an easy, fast and very intuitive way. **Includes a data-logging system** to store full welding data, downloadable through a **USB port** straight into **PDF files**. The EASY LIFE system has the capability store **up to 4000 joint reports**
- Two innovative **lateral rollers** that can be operated by a cordless drill
- **Control panel for hydraulic movements**

DELTA 630 TRAILER allows to easily weld fittings like elbows, tees, Y-branches and stub flanges.

STANDARD COMPOSITION

- Machine body complete with:
hydraulic power unit, EASY LIFE control panel, control panel for hydraulic movements, facer and bag with all necessary tools
- Heating plate TP DELTA 630 TE
- Lateral pipe lifts

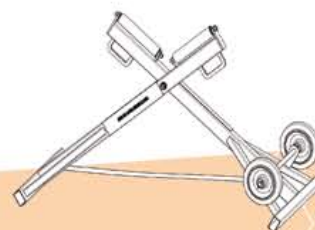

TECHNICAL FEATURES

| | |
|---------------------------|--|
| Working range | 8" IPS + 24" DIPS (225 ÷ 630 mm) |
| Power supply | 230 V or 400 V Th.ph 50/60 Hz |
| Total absorbed power | 9300 W |
| Working temperature | 356° ÷ 536° F |
| Outside temperature range | 14° ÷ 104° F |
| Materials | HDPE, PP For other materials contact RITMO S.p.A. |



Easy Life control panel

| | |
|------------------------|---------------------|
| DIMENSIONS (W x D x H) | |
| Machine body | 98,4" x 73,2" x 58" |
| Trolley | 123,6" x 82,6" |

| | |
|--------------|---------|
| Weight | |
| Machine body | 2910 lb |
| Trolley | 960 lb |

ON REQUEST (ACCESSORIES)

- Clamps' inserts from
Ø 8" IPS to 24" IPS
Ø 8" DIPS to 20" DIPS
Ø 225 to 630 mm
- Tool for flange necks
- Kit for IN-DITCH use
- Trolley
- Kit hoist
- Metal cage for transport machine body/trolley
- Kit printer
- HS ROLLERS 630
- Panel with manual control



INDIA



HS ROLLERS

HIGH STAND ROLLERS, this device is essential for supporting the pipes while they are being welded with the butt fusion machines. The rollers minimise pipe friction and drag force no matter which is the construction site condition. Special design for All Terrain / Trailer Line.



HS ROLLERS 250

Working range max: Ø 8" (250 mm)
Overall dimension: 45" x 20" x 30" (W x D x H)
Weight: 57 lb
Weight capacity: 1100 lb

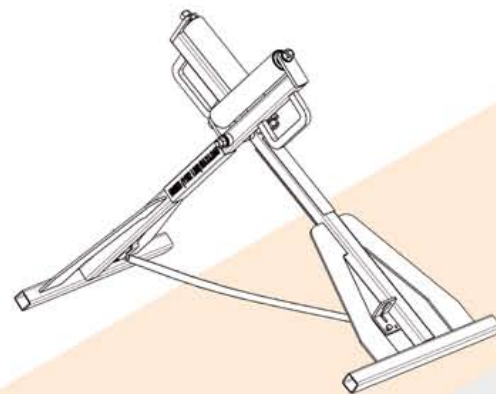
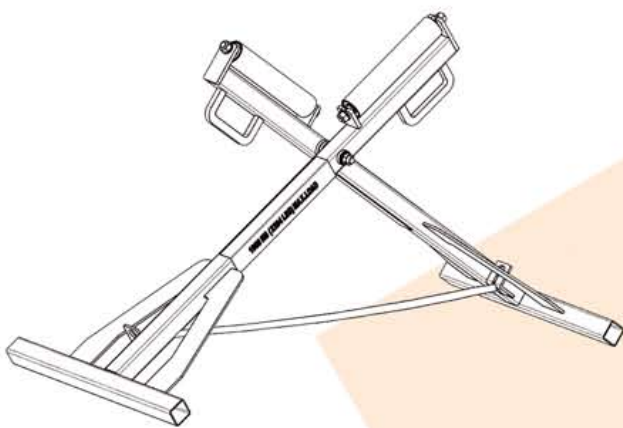

HS ROLLERS 355

Working range max: Ø 14" (355 mm)
Overall dimension: 56" x 23,5 x 32" (W x D x H)
Weight: 72,5 lb
Weight capacity: 2200 lb

HS ROLLERS 630

Working range max: Ø 24" (630 mm)
Overall dimension: 69,5" x 31,5" x 38,5" (W x D x H)
Weight: 121 lb
Weight capacity: 4400 lb

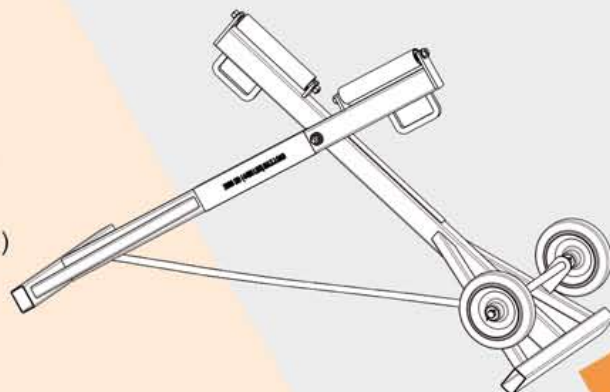

DOWNLOAD

SET & GO!

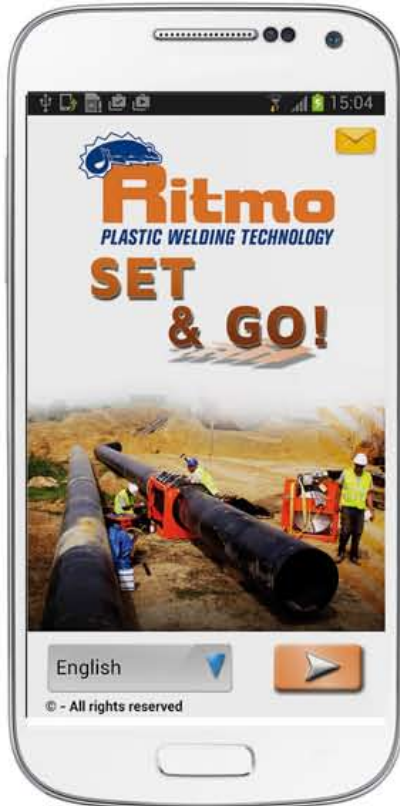

APP developed by RITMO for its butt fusion machines.

“SET & GO” calculates the welding parameters in a simple, fast and useful way.

Through easy steps, like selecting the machine model, setting up the pipe data and choosing the welding standard, “SET & GO” tells you immediately your welding parameters!

The welding cycle is assisted and guided, step-by-step, by a handy timer with countdown function

“SET & GO” ...set to the future!

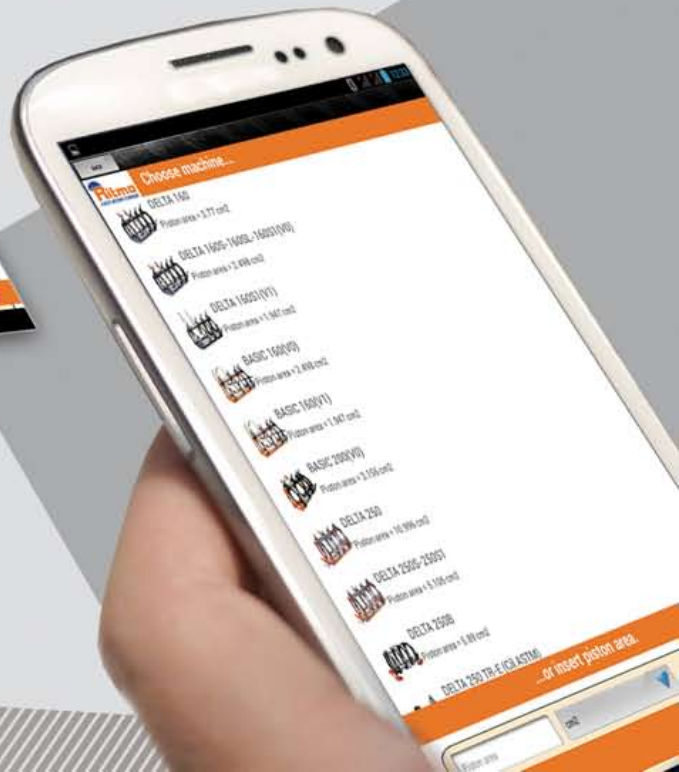

BUTT FUSION MACHINES REFERENCE

| MODEL | 32 | 40 | 50 | 56 | 63 | 75 | 90 | 110 | 125 | 140 | 160 | 180 | 200 | 225 | 250 | 280 | 315 | 355 | 400 | 450 | 500 | 560 | 630 | 710 | 800 | 900 | 1000 | 1200 | 1400 | 1600 | |
|-----------------------|----|----|----|----|----|----|----|-----|-----|-----|-----|-----|-----|-----|-----|-----|-----|-----|-----|-----|-----|-----|-----|-----|-----|-----|------|------|------|------|--|
| Millimeters | | | | | | | | | | | | | | | | | | | | | | | | | | | | | | | |
| DELTA 160 M | | | | | | | | | | | | | | | | | | | | | | | | | | | | | | | |
| BASIC 160 EASY LIFE | | | | | | | | | | | | | | | | | | | | | | | | | | | | | | | |
| DELTA DRAGON 160 | | | | | | | | | | | | | | | | | | | | | | | | | | | | | | | |
| BASIC 200 EASY LIFE | | | | | | | | | | | | | | | | | | | | | | | | | | | | | | | |
| DELTA DRAGON 250 B | | | | | | | | | | | | | | | | | | | | | | | | | | | | | | | |
| DELTA 250 TRAILER | | | | | | | | | | | | | | | | | | | | | | | | | | | | | | | |
| BASIC 315 EASY LIFE | | | | | | | | | | | | | | | | | | | | | | | | | | | | | | | |
| DELTA 355 ALL TERRAIN | | | | | | | | | | | | | | | | | | | | | | | | | | | | | | | |
| DELTA 355 TRAILER | | | | | | | | | | | | | | | | | | | | | | | | | | | | | | | |
| BASIC 355 EASY LIFE | | | | | | | | | | | | | | | | | | | | | | | | | | | | | | | |
| DELTA DRAGON 355 B | | | | | | | | | | | | | | | | | | | | | | | | | | | | | | | |
| COMPACT 355 L | | | | | | | | | | | | | | | | | | | | | | | | | | | | | | | |
| DELTA 500 | | | | | | | | | | | | | | | | | | | | | | | | | | | | | | | |
| DELTA 500 EASY LIFE | | | | | | | | | | | | | | | | | | | | | | | | | | | | | | | |
| DELTA 500 ALL TERRAIN | | | | | | | | | | | | | | | | | | | | | | | | | | | | | | | |
| DELTA 500 TRAILER | | | | | | | | | | | | | | | | | | | | | | | | | | | | | | | |
| DELTA 630 TRAILER | | | | | | | | | | | | | | | | | | | | | | | | | | | | | | | |
| DELTA 630 ALL TERRAIN | | | | | | | | | | | | | | | | | | | | | | | | | | | | | | | |
| DELTA 630 | | | | | | | | | | | | | | | | | | | | | | | | | | | | | | | |
| DELTA 630 EASY LIFE | | | | | | | | | | | | | | | | | | | | | | | | | | | | | | | |
| DELTA 800 | | | | | | | | | | | | | | | | | | | | | | | | | | | | | | | |
| DELTA 1000 TRAILER | | | | | | | | | | | | | | | | | | | | | | | | | | | | | | | |
| DELTA 1000 | | | | | | | | | | | | | | | | | | | | | | | | | | | | | | | |
| DELTA 1200 | | | | | | | | | | | | | | | | | | | | | | | | | | | | | | | |
| DELTA 1600 | | | | | | | | | | | | | | | | | | | | | | | | | | | | | | | |
| Millimeters | | | | | | | | | | | | | | | | | | | | | | | | | | | | | | | |





RITMO AMERICA LLC

300 Acuff Road - Lake Wales FL 33859
Phone 863-679-8655 Fax 863-679-8685
www.ritmoamerica.com - info@ritmoamerica.com



RITMO S.p.A.

Via A. Volta, 35/37 - 35037 Bressio di Teolo (PADOVA) ITALY
Ph. +39 049 9901888 Fax +39 049 9901993
info@ritmo.it - www.ritmo.it



Watch
the Corporate Video